

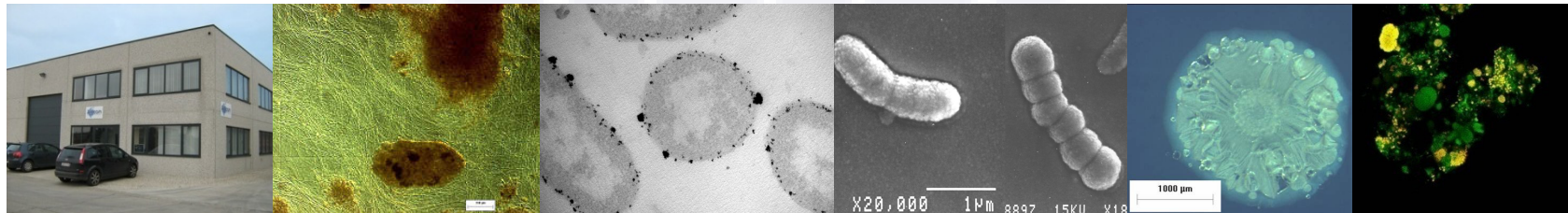

AVECOM
www.avecom.be

Industrieweg 122P
9032 Wondelgem
Belgium



- AVECOM = **A**dded **V**alue **E**nvironmental **COM**posites
- Spin off since 1996 of the Laboratory of Microbial Ecology and Technology (LabMET), Ghent Univeristy, Belgium
- Independent Business and Legal Entity
- << **Steering and optimizing microbiological processes** >>



3 BUSINESS UNITS

- **Products and Processes Unit:** Development of composites for biological wastewater treatment, process steering and optimization, feasibility and remediation tests for wastewater and sludge treatment at lab-scale and at pilot-scale
- **Soil Unit:** Feasibility tests, degrading inocula, monitoring microbial populations, consulting pilot-scale and full-scale remediation (eg: Tessenderlo Chemie), reactor development
- **R&D Unit:** Biologically produced nano catalysts

3 BUSINESS UNITS

- **Products and Processes Unit:** Development of composites for biological wastewater treatment, process steering and optimization, feasibility and remediation tests for wastewater and sludge treatment at lab-scale and at pilot-scale
- **Soil Unit:** Feasibility tests for degradation of soil pollutants, pollutant-degrading inocula, monitoring microbial populations, consulting pilot-scale and full-scale remediation (eg: Tessenderlo Chemie), reactor development
- **R&D Unit:** Biologically produced nano catalysts

- **Products:** Solid or liquid composites to improve the performance of aerobic or anaerobic wastewater treatment plants
- **Cultures:** Liquid mixtures of bacteria for seeding of aerobic or anaerobic processes (wastewater treatment, drinking water production, aquaculture, ...)
- **Processes:** Biological (aerobic and anaerobic) and physico-chemical water treatment, sludge treatment, tertiary treatment (membranes, UV, ozonisation, ...) and innovative technologies

- **Products:** Solid or liquid composites to improve the performance of aerobic or anaerobic wastewater treatment plants
- **Cultures:** Liquid mixtures of bacteria for seeding of aerobic or anaerobic processes (wastewater treatment, drinking water production, aquaculture, ...)
- **Processes:** Biological (aerobic and anaerobic) and physico-chemical water treatment, sludge treatment, tertiary treatment (membranes , UV, ozonisation, ...) and innovative technologies

Aerobic Treatment of wastewater

- **Nutriflok:** Solid product to improve the environmental conditions to favour the useful bacterial groups. The mixture is based on a premix of vitamins/minerals/ nutrients
- **Nutriflok 50S:** Nutriflok + floc enhancing additives
- **Empower:** Solid product for bio-chemical P removal and better sludge activity
- **Stabilox:** Liquid product based on minerals and trace elements



Anaerobic Treatment of

- **Methanostim** : Solid bulk based on a premix of vitamins/minerals/nutrients
- **Methanostim Liquide**: Liquid product based on a mixture of minerals and trace elements

→ **New opportunities:**

- **Foam quenching**
- **Enhanced hydrolysis**
- **Enrichment of propionic acid degraders**

- **Products:** Solid or liquid composites to improve the performance of aerobic or anaerobic wastewater treatment plants
- **Cultures:** Liquid mixtures of bacteria for seeding of aerobic or anaerobic processes (wastewater treatment, drinking water production, aquaculture, ...)
- **Processes:** Biological (aerobic and anaerobic) and physico-chemical water treatment, sludge treatment, tertiary treatment (membranes, UV, ozonisation, ...) and innovative technologies

- **Aerobic**
 - **ABIL** (quarantained production): AOB (ammonia oxidizing bacteria) and NOB (nitrite oxidizing bacteria) for aquaria and biofilters for aquaculture and drinking water production
 - **HANDS**: Highly Active Nitrifying and Denitrifying Sludge for seeding of full-scale aerobic wastewater treatment reactors
 - **Lyposol**: Highly active biological degreaser for restaurants and industrial kitchens
- **Anaerobic**
 - **Granular Sludge** (mesophilic) for seeding of full-scale anaerobic wastewater treatment reactors

- **Products:** Solid or liquid composites to improve the performance of aerobic or anaerobic wastewater treatment plants
- **Cultures:** Liquid mixtures of bacteria for seeding of aerobic or anaerobic processes (wastewater treatment, drinking water production, aquaculture, ...)
- **Processes:** Biological (aerobic and anaerobic) and physico-chemical water treatment, sludge treatment, tertiary treatment (membranes , UV, ozonisation, chemical oxidation,...) and innovative technologies

Water treatment in general

- Development of new additives (tailor-made)
- Feasibility, activity, toxicity tests (lab- or pilot-scale)
- Consulting on operating parameters (full-scale)
- Sludge characterization
- Follow up of microbial populations (CFU, microscopy, PCR, DGGE, Live/Dead)

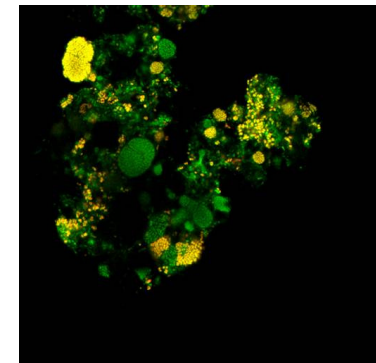
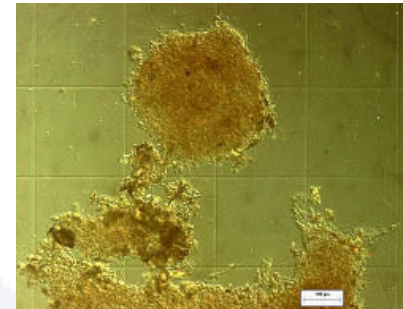

3 BUSINESS UNITS

- Products and Processes Unit: Development of composites for biological wastewater treatment, process steering and optimization, feasibility and remediation tests for wastewater and sludge treatment at lab-scale and at pilot-scale
- **Soil Unit: Feasibility tests, degrading inocula, monitoring microbial populations, consulting pilot-scale and full-scale remediation (eg: Tessenderlo Chemie), reactor development**
- R&D Unit: Biologically produced nano catalysts

- Feasibility tests: Biodegradation, ISCO, ISCR, ISBP, BioPAD
- Monitoring bacterial populations: Bacterial counting, PCR, DGGE
- Products: Degrading inocula (eg. Multidechlorobac)
- Consulting pilot and full scale remediation and executing pilot tests
- Reactor development

- **Feasibility tests: Biodegradation, ISCO, ISCR, ISBP, BioPAD**
- Monitoring bacterial populations: Bacterial counting, PCR, DGGE
- Products: Degrading inocula (eg. Multidechlorobac)
- Consulting pilot and full scale remediation and executing pilot tests
- Reactor development

- Feasibility tests for the biodegradation of
 - VOCs
 - Mineral oil
 - Creosote
 - BTEX
 - PAHs
 - PCBs
 - ...



- Bottlenecks/optimal conditions
- ➔ Tailor made bioremediation solutions

Soil Unit – Feasibility tests

- Feasibility tests for In Situ Chemical Oxidation (ISCO)
 - Permanganate
 - Persulphate
 - Fenton's Reagent
 - ...
- Feasibility tests for In Situ Chemical Reduction (ISCR)
- Feasibility tests for In Situ Bio-Precipitation (eg sulphate reduction) (ISBP)
- Feasibility tests with our biochemical based reductantia (Bio-Palladium, BioPAD)
- BioPAD: Nanopalladium on cellwall of bacteria
- Degradation PCBs, VOCs, Lindane, ...

- Feasibility tests: Biodegradation, ISCO, ISCR, ISBP, BioPAD
- **Monitoring bacterial populations: Bacterial counting, PCR, DGGE**
- Products: Degrading inocula (eg. Multidechlorobac)
- Consulting pilot and full scale remediation and executing pilot tests
- Reactor development

Soil Unit – Monitoring bacterial populations

- Bacterial counting
- PCR : detection and/or quantification of specific bacteria in soil or groundwater (*Dehalococcoides*, *Dehalobacter*, *Desulfitobacter*,...)
- DGGE : verifying shifts in microbial community

- Feasibility tests: Biodegradation, ISCO, ISCR, ISBP, BioPAD
- Monitoring bacterial populations: Bacterial counting, PCR, DGGE
- **Products: Degrading inocula (eg. Multidechlorobac)**
- Consulting pilot and full scale remediation and executing pilot tests
- Reactor development

- Development of pollutant degrading inocula
 - Multidechlorinating inoculum - Multidechlorobac
 - Combined degradation of 1,2-DCA and chlorinated ethenes !

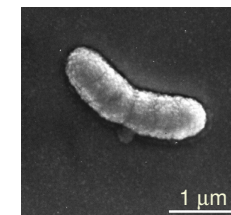
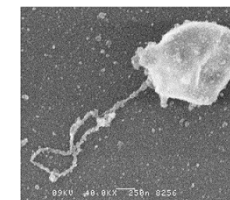
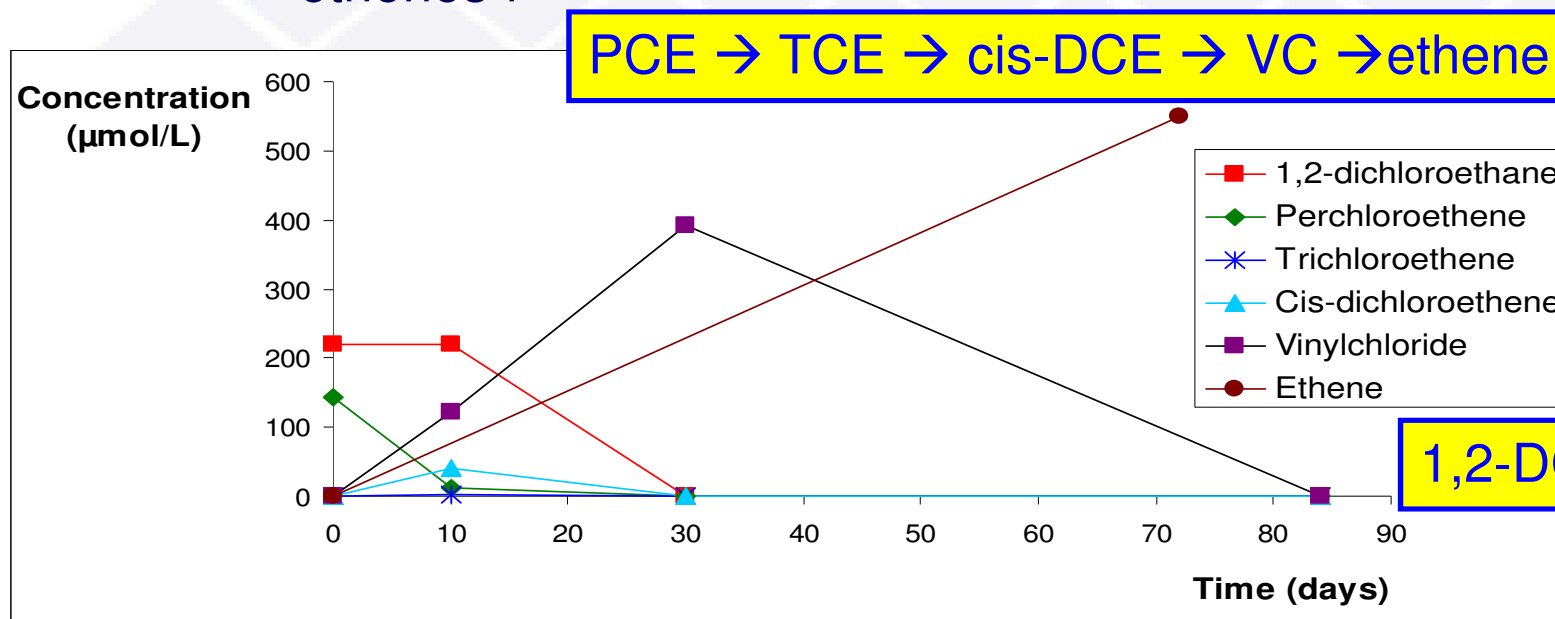

- Inoculum for MTBE-degradation

- Feasibility tests: Biodegradation, ISCO, ISCR, ISBP, BioPAD
- Monitoring bacterial populations: Bacterial counting, PCR, DGGE
- Products: Degrading inocula (eg. Multidechlorobac)
- **Consulting pilot and full scale remediation and executing pilot tests**
- Reactor development

Soil Unit – Consulting + pilot tests

- Consulting for the application of the lab results to pilot and full scale remediation
 - Tessengerlo Chemie



- Life+ Innovative soil remediation technique for the degradation of chlorinated solvents
 - Multidechlorobac
 - HydroGeoBioCel: artificial groundwater flow
 - Site: Tessenderlo Chemie



- Feasibility tests: Biodegradation, ISCO, ISCR, ISBP, BioPAD
- Monitoring bacterial populations: Bacterial counting, PCR, DGGE
- Products: Degrading inocula (eg. Multidechlorobac)
- Consulting pilot and full scale remediation and executing pilot tests
- **Reactor development**

- Reactors

- Bio-Palladium membrane reactor

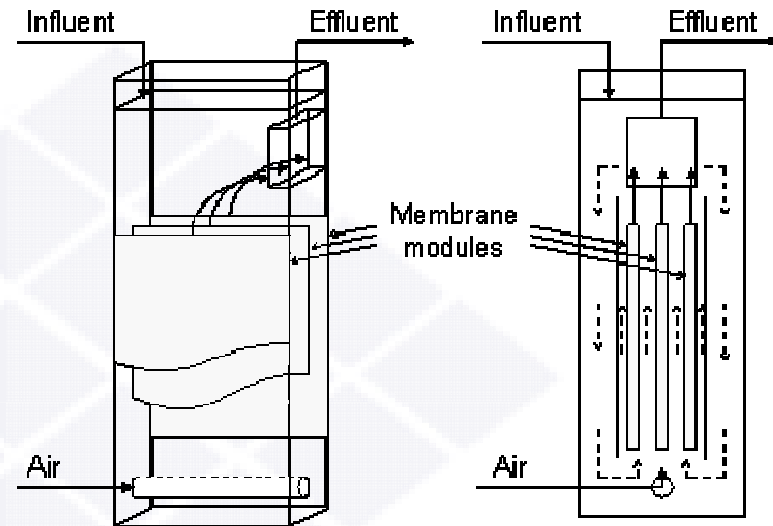

- Bioreactor with Multidechlorobac/MTBE-inoculum

3 BUSINESS UNITS

- Products and Processes Unit: Development of composites for biological wastewater treatment, process steering and optimization, feasibility and remediation tests for wastewater and sludge treatment at lab-scale and at pilot-scale
- Soil Unit: Feasibility tests, degrading inocula, monitoring microbial populations, consulting pilot-scale and full-scale remediation (eg: Tessenderlo Chemie), reactor development
- **R&D Unit: Biologically produced nano catalysts**

Biogenically produced nano catalysts

- Palladium
- Silver
- Gold
- Iron
- ...

Applications in environmental remediation,
chemical catalysis, ...

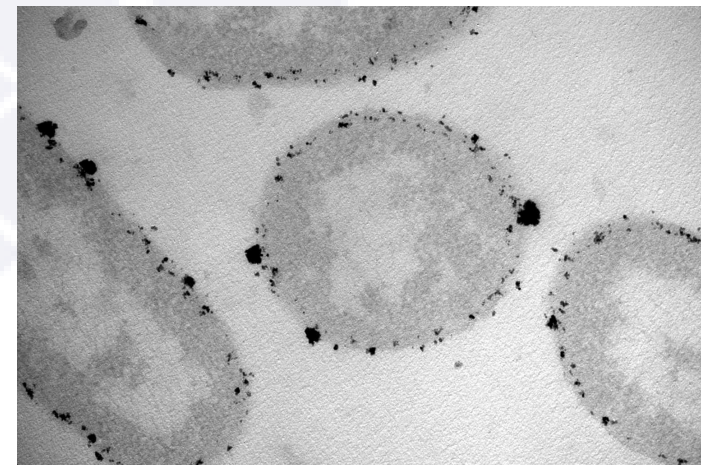



Contact information

Industrieweg 122P
9032 Wondelgem
Belgium

Tel: +32 9 375 17 14

Fax: +32 9 375 17 15

E-mail: info@avecom.be

Direct contacts: see website www.avecom.be